



Anaerobic Digester at Noblehurst Farms, Inc.: Case Study

Peter Wright and Jianguo Ma

Dept. of Biological and Environmental Engineering, Cornell University

November 2003

Who Should Consider a System Like This?

- Farms in need of odor control.
- Farms where manure can be collected easily.
- Farms with capital available for initial start up costs.
- Farms with technical interest and skills for the system operation and maintenance.
- Farm with adequate cropland for the nutrients.

Farm Information

Noblehurst Farms, Inc. is a 1,100 milking cow commercial dairy located in Livingston County. Managed by Robert Noble, it also has a stock of 200 heifers and 250 calves on the 2,000-acre farm. In January 2003, Noblehurst Farms, Inc. began operating a farm-based anaerobic digester power system to address a variety of issues and improve its business viability.

Why the Digester?

The management of Noblehurst Farms had several reasons for choosing to build an anaerobic digester. Environmental concerns were a high priority as the farm is sited in two watersheds that provide primary drinking water for surrounding communities. Traditionally manure was spread daily on crop fields and as a result, pollution from pathogens and nutrient loading was a concern in these watersheds. Long-term storage could create greater odor issues in a community that already had expressed their objection to existing odors from the intensive dairy farming in the area.

As increasing pressure from environmental regulations and the surrounding community increased, Noblehurst considered a centralized digester for better manure management. When the centralized study (*Evaluation of Anaerobic Digestion Options for Groups of Dairy Farms in Upstate New York*, by W. J. Jewell, et. al., 1997) suggested a system containing only one or two farms to be the best alternative, Noblehurst decided on a single-farm anaerobic digester. The reasoning behind this was to better utilize the electricity produced and to keep transportation costs down. The digester was sized for their farm with room for future expansion. It not only addresses the environmental issues, but also provides economic and energy benefits. The project



was budgeted for \$648,830. Obtaining a cost-sharing contract from the New York State Energy Research and Development Authority (NYSERDA) helped move the project forward.

The project goals are to install a cost-effective system, which can demonstrate the following benefits:

- Odor reduction
- Pathogen reduction
- Nutrient control
- Reduction of methane emissions
- Reduction in volatile solids introduced into storage tanks/ponds
- Electricity savings and sales
- Heating savings

Construction on the digester started in summer 2001, and an engine-generator set was installed and began operating on January 15, 2003.

Digester System

System and Process Description

The digester system on Noblehurst Farm includes several subsystems (see Figure 1):

- Manure collection
- Twin digesters for manure digestion and biogas production
- Engine generator set
- Separator to separate liquids and solids after the manure is digested (still under construction)
- Liquid storage (existing)

The Noblehurst plug-flow digester is a rectangular, in-ground concrete tank (120' x 50' x 16') consisting of two digesters separated by a concrete wall (see Figure 1). Manure is scraped from each barn to a central flow channel, where it flows to a collection pit (approximately 28,000 gallons) located on the east side of the barns, adjacent to an existing concrete manure storage facility. Manure from this collection pit is mixed with digested effluent to obtain 10% dry matter content, and then pumped to the influent manifold of the digester. The flow is distributed essentially equally to the two parallel digesters twice a day. As manure is displaced in the digesters, it flows to the effluent chamber.

With 1,100 milkers plus 200 heifers onsite, the manure production is estimated to be 28,000 gal/day or 10,220,000 gal/year. The retention time of the digester is about 25 days. The Noblehurst digester has a flat concrete cover made of prestressed concrete panels covered with concrete, insulation and earth. The digester is sealed from inside to prevent biogas leakage and insulated to maintain temperature. A 15" water column pressure was developed in the digester to avoid compressing the biogas when feeding the engine. A sediment trap with suction pump access was built inside the digester to clean any accumulated grit. Once the separator building is completed and other necessary equipment is installed, manure will be pumped from the effluent chamber to an elevated separator. The separated solids will be composted and used as soil

amendment in the cropping program or sold. The separated liquids will flow to the concrete storage by gravity. Some of the liquids may be recycled to get an appropriate solids content entering the digester. The rest of the liquids will be land applied in accordance with CAFO plans.

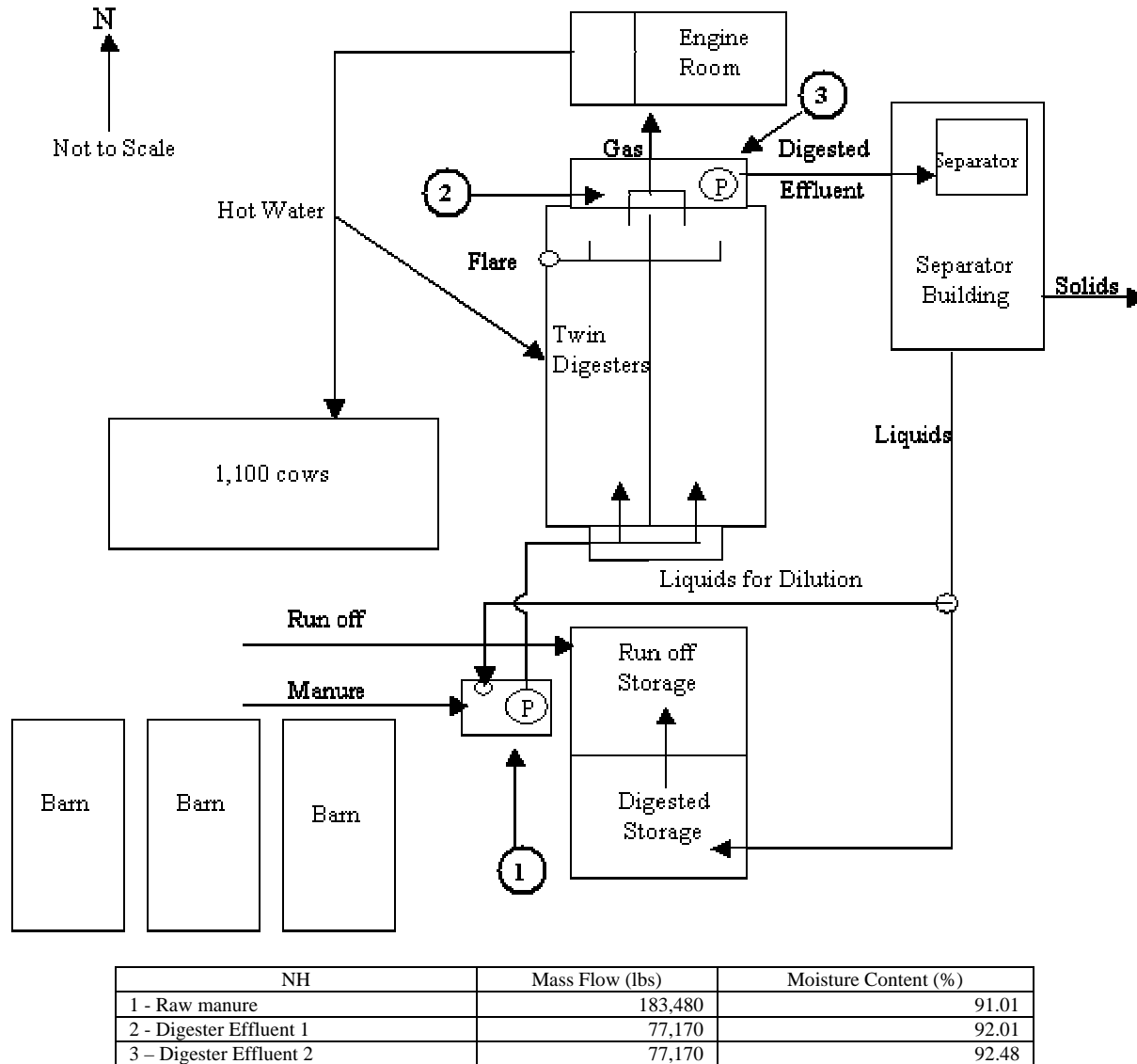

Figure 1. Schematic of Noblehurst Anaerobic Digester System

Heat and Electricity Generated

It is estimated that the biogas production is about 72,000 ft³ per day. Biogas is collected from the digesters and fed to the engine. The engine (Caterpillar 3406NA, 285 HP) is attached to a generator (Marathon 447) with a capacity of 130 kW. Hot water from the engine is used to maintain the digester temperature and for other on-farm hot water needs. A radiator releases excess heat.

The engine generator consumes biogas at a rate of approximately 60,000 ft³/day, or about 55 ft³/cow/day. This biogas consists of methane (about 60%), carbon dioxide (about 40%), a small amount of sulfide compounds, and other trace gases. The generator output varies. It has run as high as 100 kW and as low as 60 kW. The engine-generator set roughly has an electricity production of 788,400 kWh/year based on 90 kW output.

Economic Information

	Items	Cost/Benefit *
Capital Costs	Digester	
	- Digester Construction and Materials	\$250,000
	- Cover for digester	\$60,000
	Subtotal	\$310,000
	Engine-Generator Set	
	- Engine Generator	\$241,000
	- Switching Equipment	\$18,000
	- Engine Building	\$43,500
	Subtotal	\$302,500
	Manure Storage	\$60,000
Annual Operating Costs	Solids and Liquids Separation	
	- Separator	\$26,000
	- Separator Building	\$35,000
	Subtotal	\$61,000
	Others (flare, pumps)	\$14,200
	Total Capital Cost	\$747,700
	Total Capital Cost per cow	\$680
Total Annual Capital Cost	\$68,522	
Annual Operating Costs	Maintenance, Repairs, Labor, Fuel, Insurance, etc.	\$37,675
	Manure Spreading Cost (@0.005/gallon)	\$51,000
Annual Benefits	Electricity Savings and Sales (projected)	-\$60,000
	Heating Fuel Savings (projected)	-\$6,000
	Compost sale (projected sales @ net \$2/cubic yard)	-\$11,680
	Odor Control (@\$9/cow/year)	-\$9,900
	Total Annual Benefits	-\$77,680
Annual Net Cost Per Cow (\$/cow/year)		\$50 **
Note: * - The operating costs (maintenance and repairs) and revenues are projected numbers as of November 1, 2003. An updated analysis will be provided with real data once the system is operated for one year.		
** - Manure management without digester and solids separator would cost \$50/cow.		

Advantages and Disadvantages

Advantages	Disadvantages
<ul style="list-style-type: none"> - Odor Control - Energy Production - Heating Fuel Savings - Energy Savings - Nutrient Management Ease - Pathogen Reduction 	<ul style="list-style-type: none"> - Adding Complexity to Farming - Dedication to Digester System Management (i.e. labor and maintenance)

Lessons Learned

The disadvantage of the expense of manure transportation to the community site and transportation of the effluent back to each farm was a huge cost for the community system to overcome.

Concrete hard tops operating under pressure are very difficult to seal. Leaks of biogas cause loss of gas production and odors on the farm. Pressure testing before filling with manure is time consuming and expensive but apparently needed to ensure that the sealant has been properly applied.

Complete engine skids and gas handling skids that have been factory installed to meet the specifications of the specific installation provide design and construction convenience. The systems are put together with compatible equipment and controls so on farm hassles are reduced.

The twin digester construction to avoid an excessively long digester and reasonable spans for the concrete top is a viable design. This should make it possible to shut down and start up each side independently and therefore easier. It is hard to divide the influent equally to the two digesters; a flow meter along with the control device may be needed.

Burying the exhaust pipe and outletting it some distance from the engine room keeps corrosion away from building and keeps noise down. Internal combustion engines are loud. Sound control may be needed on some sites.

Maintaining temperature control during the winter is important. Frozen manure and manure that was too wet was bypassed from the digester. When the digester feed was reduced the gas production slowed and less heat was available to heat the influent and maintain the temperature. Either added external energy would be needed to maintain the digester temperature or the digester would need several months and warmer weather to recover.

The thermometers were installed reading 3 degrees higher than reality. Checking and calibrating the instrumentation should be an important step in start up procedures.

Who to Contact

- Peter Wright, Manure Treatment Specialist, PRO-DAIRY, Cornell Cooperative Extension. Phone: 607-255-2803, Email: pew2@cornell.edu
- Dave Palmer, Designer, Cow Power Inc., Syracuse. Phone: (315) 457-8250, Email: biogas@prodigy.net

Acknowledgements

The authors would like to thank the New York State Energy Research and Development Authority (NYSERDA) for funding in support of this work. Any opinions, findings, conclusions or recommendations expressed in this publication are those of the authors and do not necessarily reflect the views of NYSERDA or the State of New York, and reflect the best professional judgment of the authors based on information available as of the publication date. Reference to any specific product, service, process, or method does not constitute an implied or expressed recommendation or endorsement of it. Further, Cornell University, NYSERDA and the State of New York make no warranties or representations, expressed or implied, as to the fitness for particular purpose or merchantability of any product, apparatus, or service, or the usefulness, completeness, or accuracy of any processes, methods, or other information contained, described, disclosed, or referred to in this publication. Cornell University, NYSERDA and the State of New York make no representation that the use of any product, apparatus, process, method, or other information will not infringe privately owned rights and will assume no liability for any loss, injury, or damage resulting from, or occurring in connection with, the use of information contained, described, disclosed, or referred to in this publication.